

Introduction

Made for moving plywood and long lumber, this 500 lb. capacity material cart has outrigger style 5" casters for maximum stability, and measures 42" long x 28½" wide x 35⅜" high. The plywood deck measures 38½" long x 16" wide.

Inventory

Base Assembly.....	1
Tubular Cart Sides	2
5" Casters.....	2
5" Left-Side Braking Casters	2
Hex Bolts M8-1.25 x 20 (Casters).....	16
Lock Washers 8mm (Casters).....	16
Flat Washers 8mm (Casters)	16
Hex Nuts M8-1.25 (Casters)	16
Hex Bolts M8-1.25 x 40 (Cart Sides)	4
Fender Washers 8 x 35 x 3mm (Cart Sides)	4

Assembly

1. Attach the casters to the base assembly with the M8-1.25 x 20 hex bolts, hex nuts, flat washers and lock washers, as shown in **Figure 2**. Both braking casters should be installed at the same end of the cart, as shown in **Figure 1**.
2. Slide the tubular ends of the cart sides into the support sockets located on the cart assembly, and fasten with the M8-1.25 x 40 hex bolts and fender washers as shown in **Figure 2**.
3. If you have difficulty moving your cart, check to see if the casters are locked in the horizontal "brake" position. Simply move the brake into the diagonal "free" position (**Figure 3**) to restore movement to the caster.



Figure 1. Model H7544.

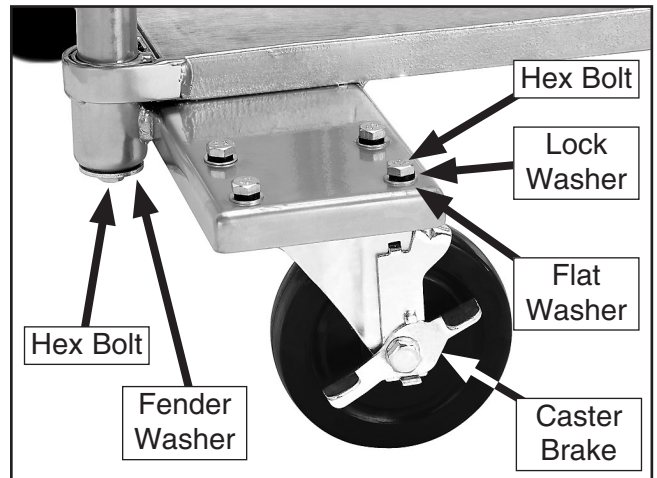
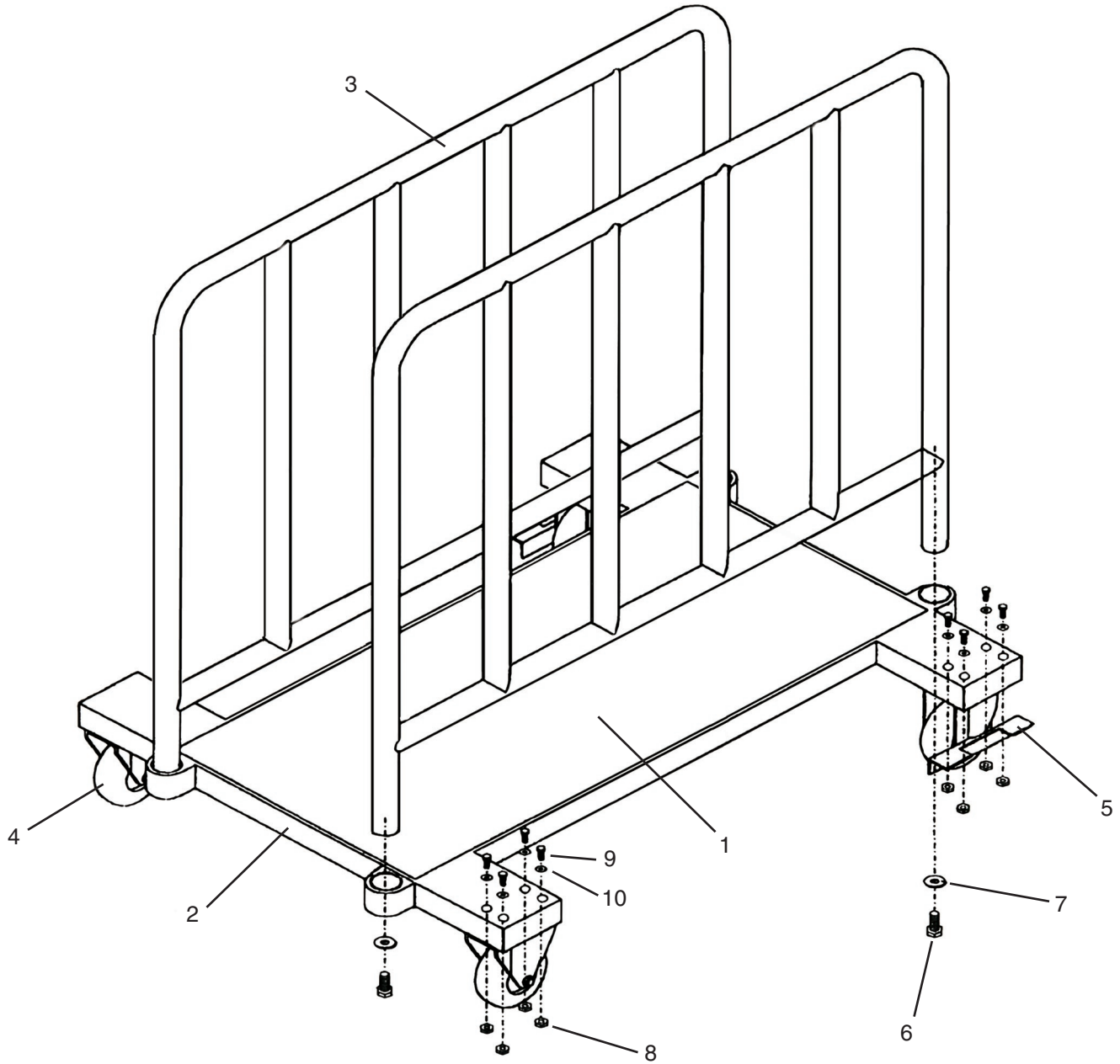

Figure 2. Model H7544 detail, showing caster in diagonal "free" position.

If you need help with your new material cart, call our Tech Support at: (570) 546-9663.

H7544 Parts Breakdown



H7544 Parts List

REF	PART #	DESCRIPTION
1	PH7544001	PLYWOOD DECK 38-1/2" X 16"
2	PH7544002	FRAME
3	PH7544003	TUBULAR SIDE
4	PH7544004	RUBBER CASTER 5"
5	PH7544005	RUBBER CASTER WITH BRAKE 5"

REF	PART #	DESCRIPTION
6	PB26M	HEX BOLT M8-1.25 X 30
7	PH7544007	FENDER WASHER 8 x 35 x 3
8	PN03M	HEX NUT M8-1.25
9	PB09M	HEX BOLT M8-1.25 X 20
10	PW01M	FLAT WASHER 8MM